



# Integration of digital voltmeters with voltage dividers and current shunts (WP2)

A. Pokatilov

DIG-AC Final Meeting, 19.-20.05.2022



## Measurement setup

- Voltage scaling from 12 V to 220 V up to 10 kHz
- 2x 8588As
  - 1 V Range, sampling mode
- 5x resistive voltage dividers
- 1x ac-dc transfer standard

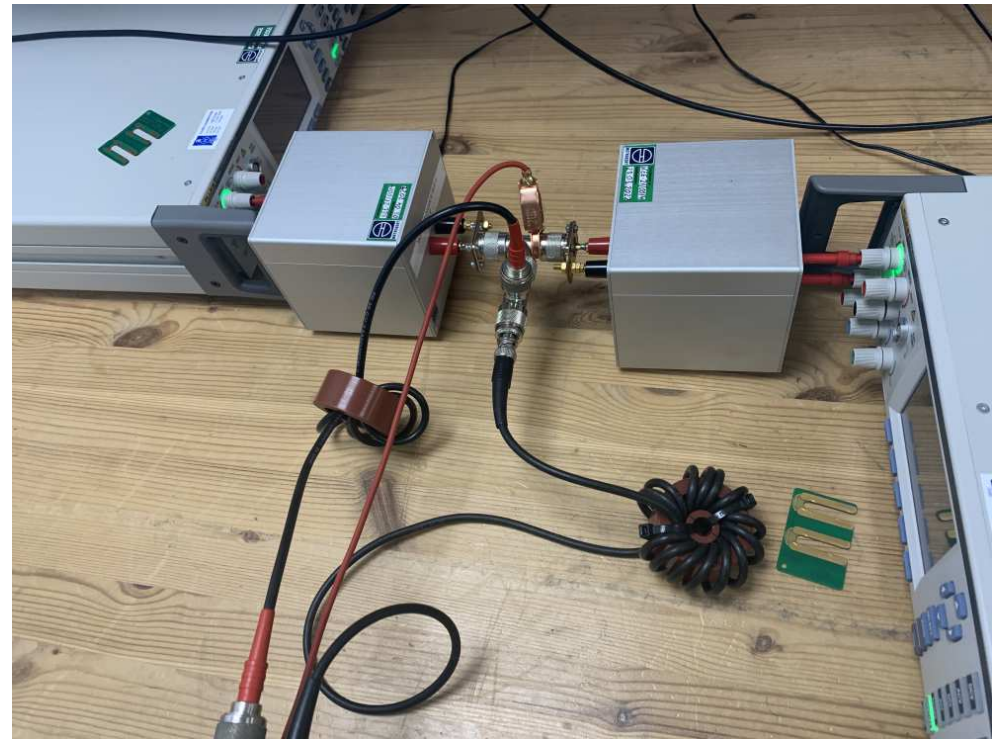

# Measurement procedure

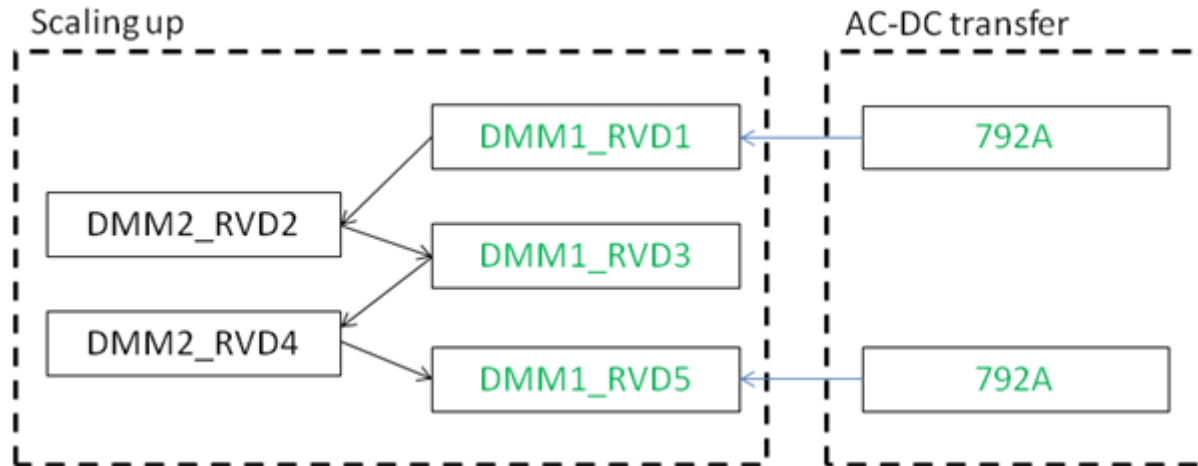

Ac-dc transfer at 12 V and 220 V

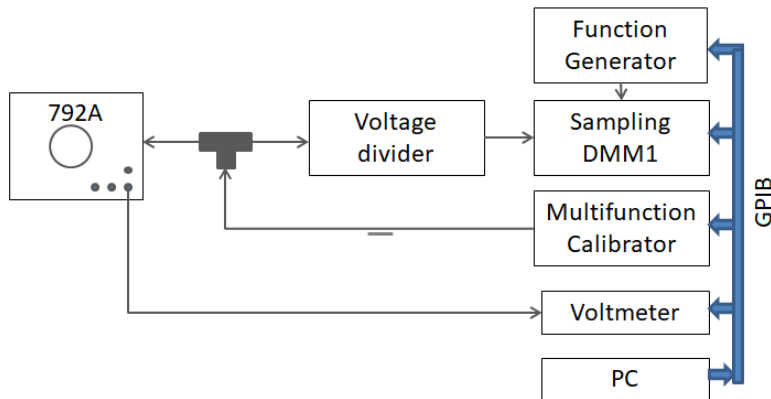

Scaling from 12 V to 220 V in four steps

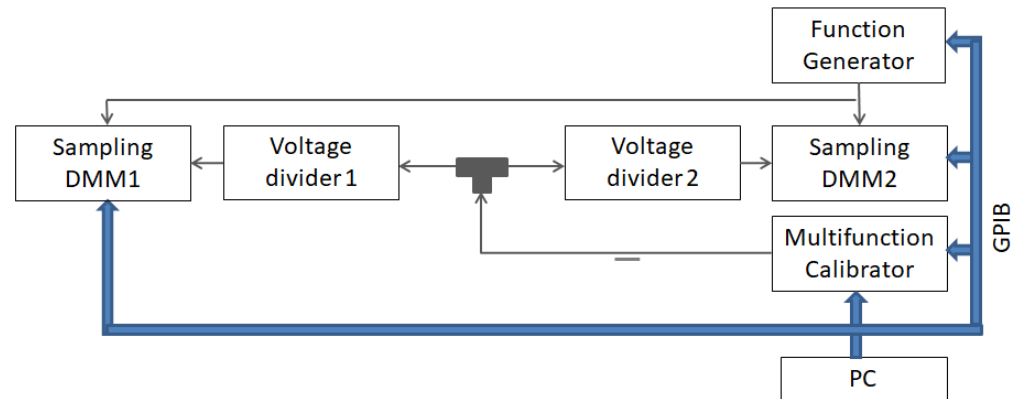

# Measurement results

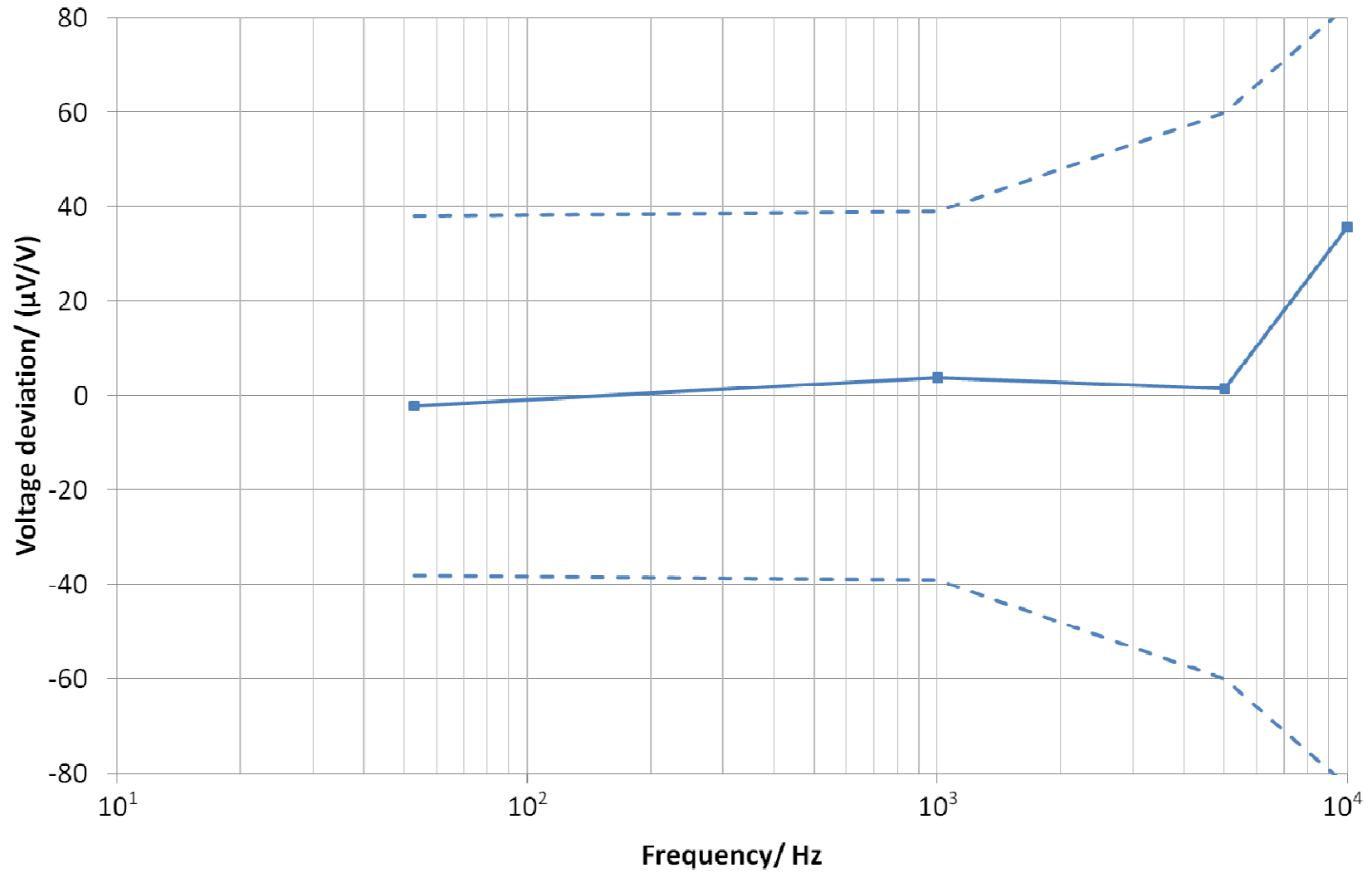

# Phase angle error of voltage divider

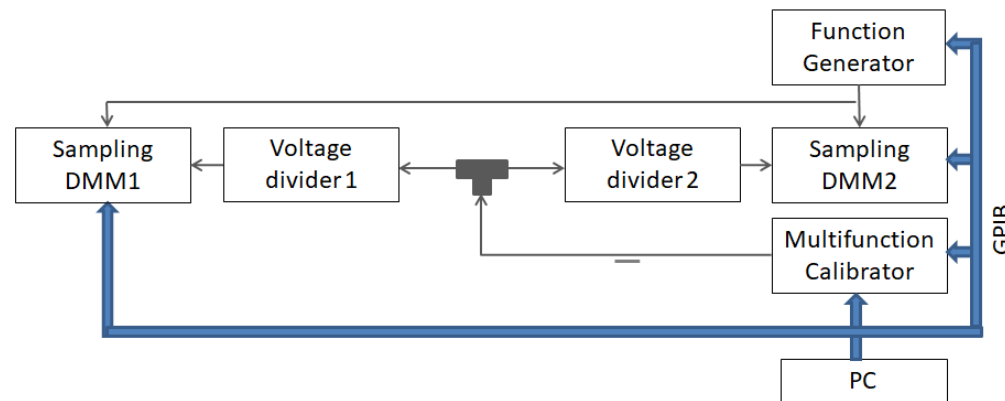
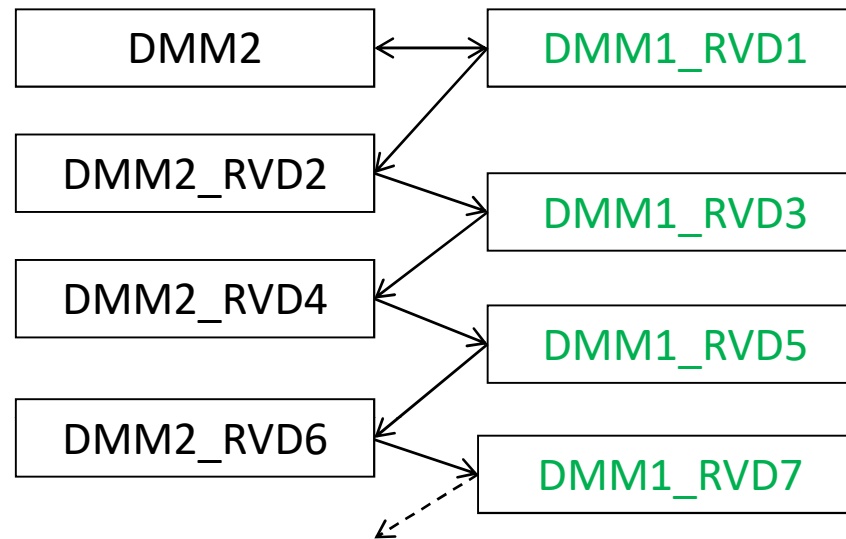

# Phase angle error of current shunt Measurement setup

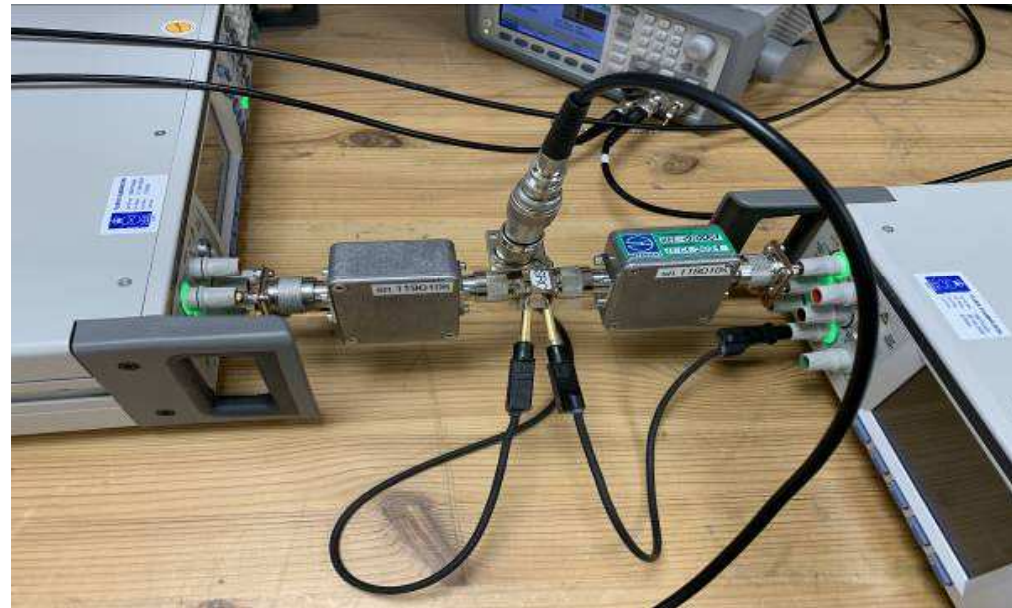
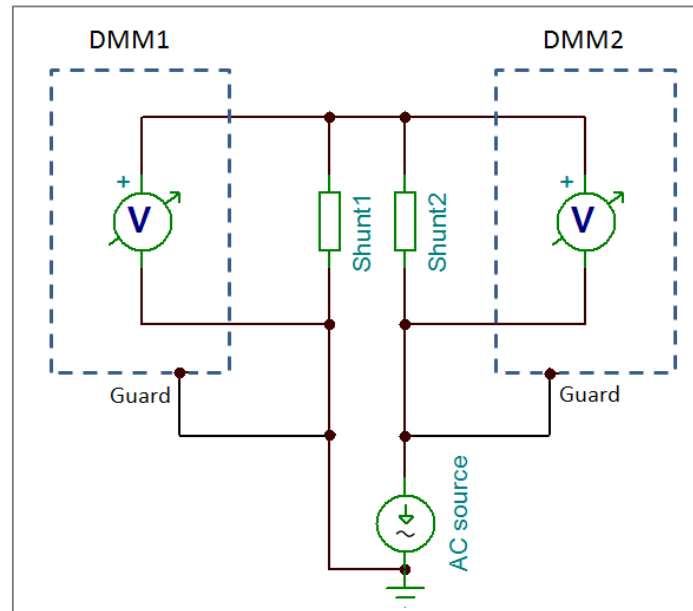

# Reference shunt and load (DMM)

Circuit diagrams of a standalone shunt and a shunt connected to a digitizer:

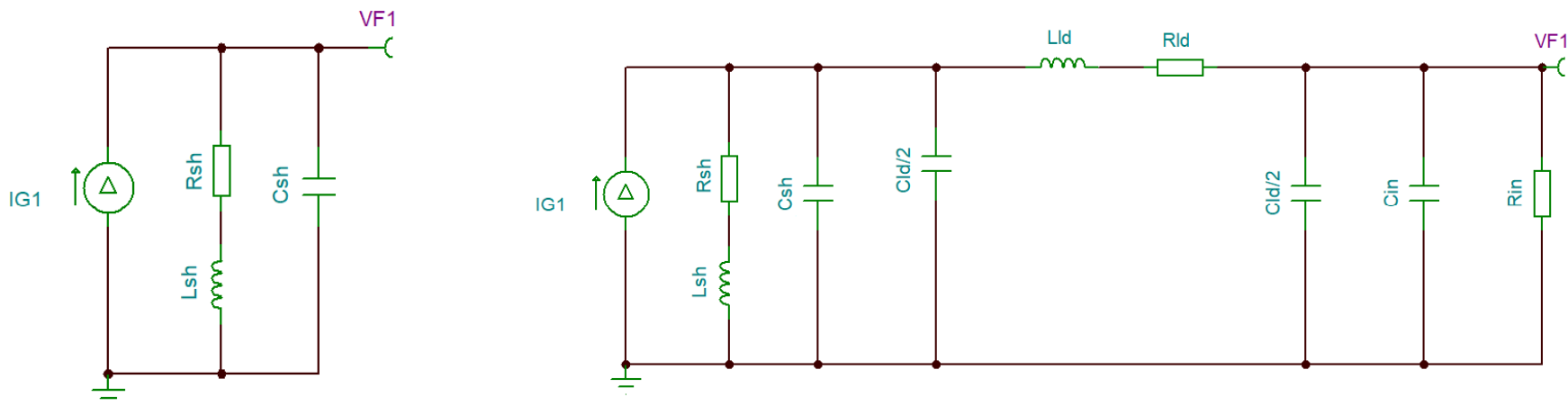

# Time constant difference measured against modelled 10 $\Omega$ and 20 $\Omega$ references

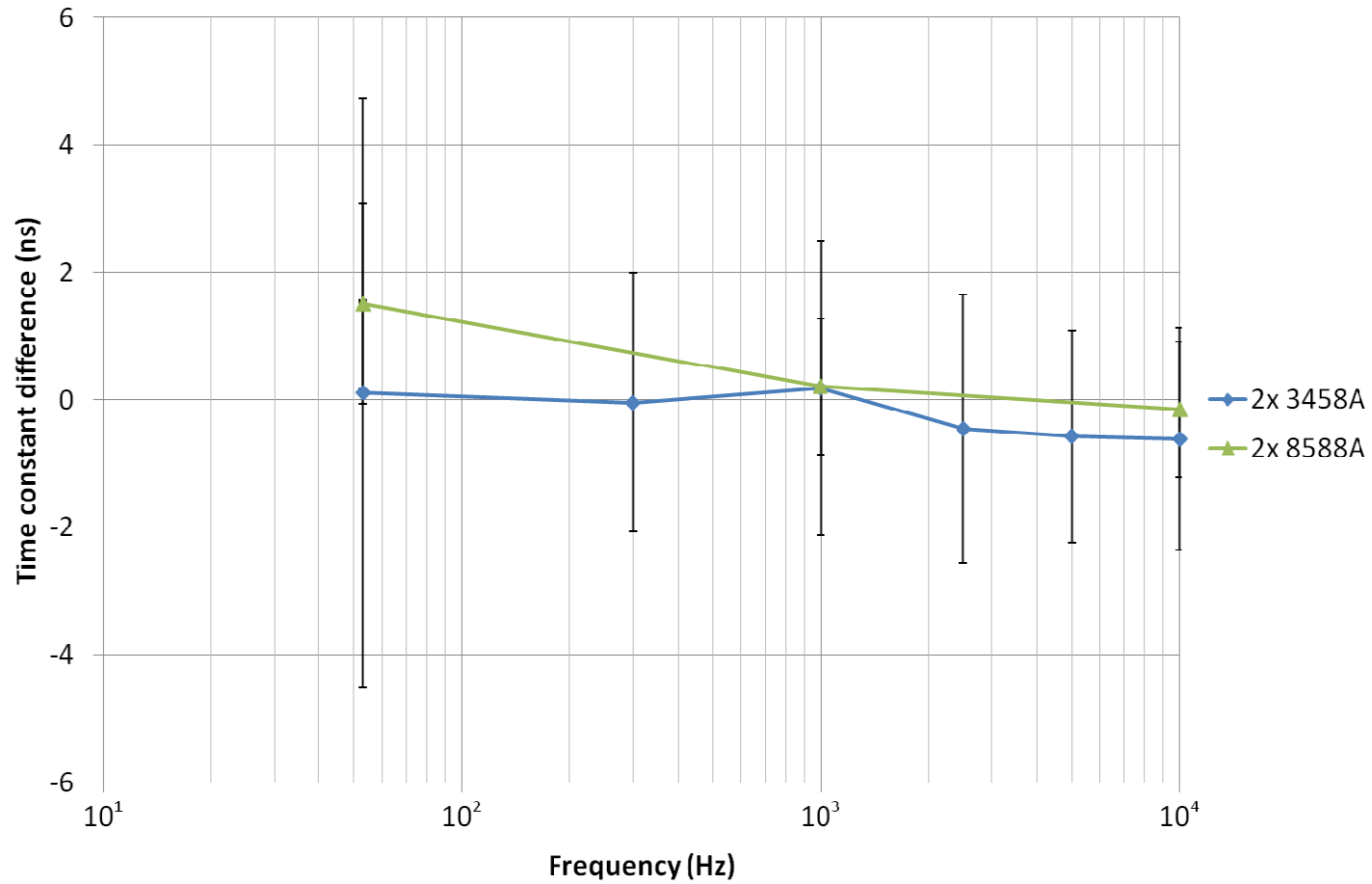

# Step-up procedure and time constant of the reference shunt

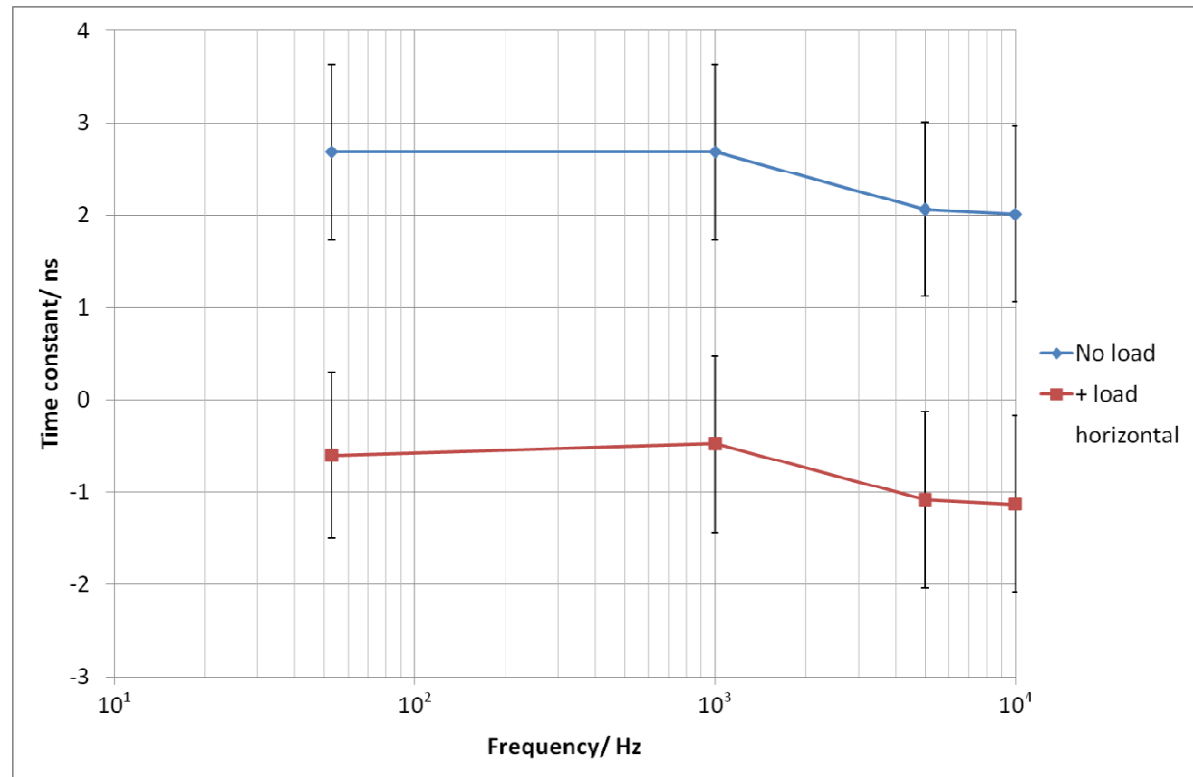
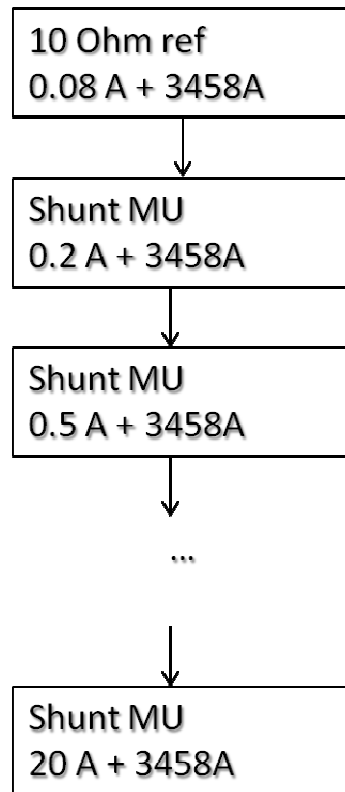



# Täna tähelepanu eest!

E-post: [andrei.pokatilov@metrosert.ee](mailto:andrei.pokatilov@metrosert.ee)

AS Metrosert

Teaduspargi 8, Tallinn

Teaduspargi 11, Tartu

Sompa 1A, Jõhvi

DIG-AC Final Meeting, 19.-20.05.2022

